

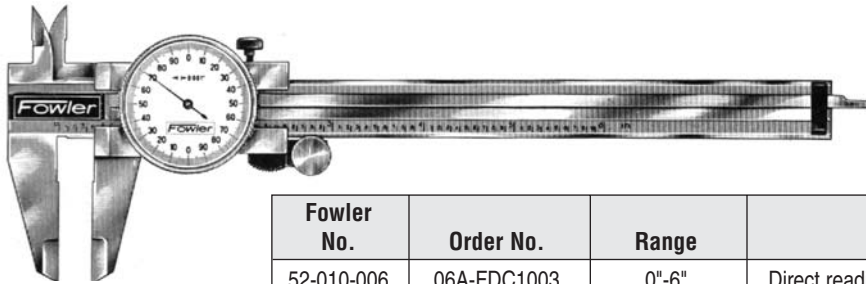

# Falcon Dial Calipers

## Inside Measuring Jaw Type



Fowler Dial Calipers have been designed to meet the standards of high precision measuring tools at a price that makes them affordable. The tools are exceptional in design and manufacturing quality standards. The smooth action, feel, balance and finish ensures their popularity with users.

Fowler No.	Order No.	Range	Description	Price*
52-010-006	06A-FDC1003	0"-6" in .001"	Direct reading stainless steel dial caliper with inside and outside jaws. Adjustable dial and depth rod. Satin chrome finish.	\$105.00
52-010-016	06A-FDC1004	0-16 cm in 1/20 mm	Same as above but in METRIC graduations.	\$116.00

\* Price includes fitted case.

## With New Adjustable Dial

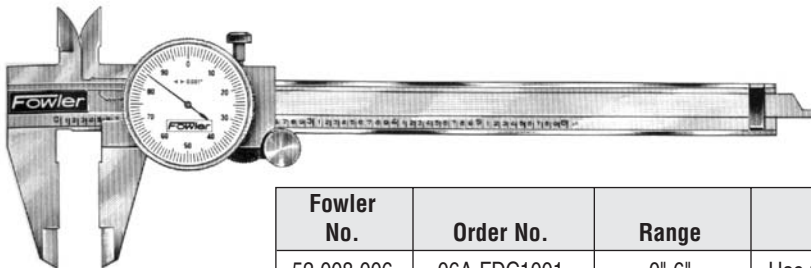

The Fowler "One-Rev" Dial Caliper combines the convenience of widely-spaced microfine graduations, the protection of a covered depth rod and the accuracy of a hardened stainless steel rack.

Fowler No.	Order No.	Range	Description	Price*
52-008-006	06A-FDC1001	0"-6" in .001"	Has new covered rack to keep out dirt. Dual pinion drive. 100 per revolution dial. Thumb roll.	\$98.00

\* Price includes fitted case.

## Heavy-Duty Dial Calipers with Fine Adjustment

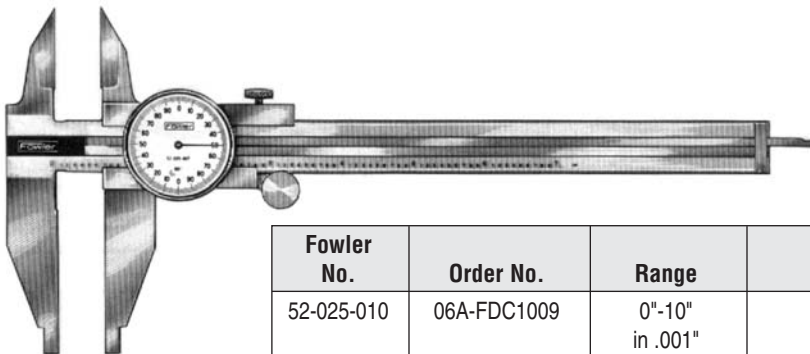

Fine German design and sturdy construction ensure a long life of reliable and accurate service in these heavy-duty calipers. Made by Helios exclusively for Fowler.

Fowler No.	Order No.	Range	Description	Price*
52-025-010	06A-FDC1009	0"-10" in .001"	Stainless steel, satin finish. Adjustable dial. Thumb roll.	\$406.00

\* Price includes fitted case.

6



## High Precision Stainless Steel Calipers

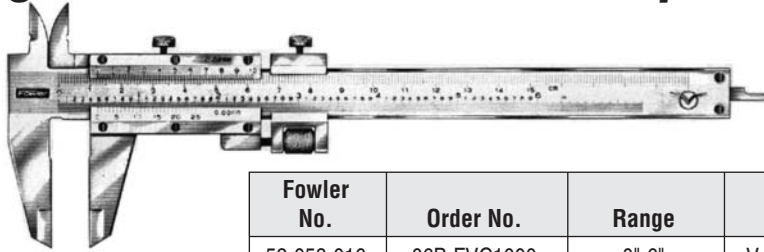

Fowler's line of fine quality vernier calipers measures accurately in inch or metric with vernier scales of .001" and .02mm.

Fowler No.	Order No.	Range	Description	Price*
52-058-016	06B-FVC1000	0"-6" by 150 mm	Vernier caliper, stainless steel, satin chrome. Jaws for outside, inside and thread measurement. Double set screw for fine adjustment.	\$39.00

\* Price includes fitted case.

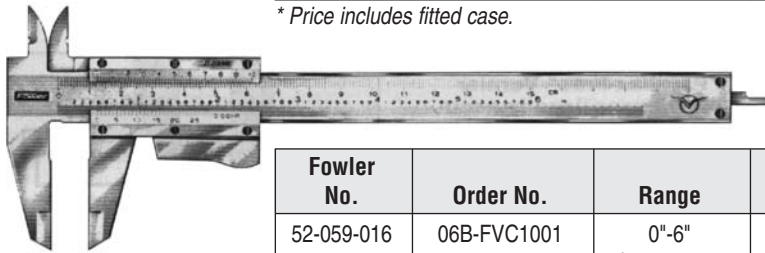

Fowler No.	Order No.	Range	Description	Price*
52-059-016	06B-FVC1001	0"-6" by 150 mm	Vernier caliper, stainless steel, satin chrome. Thumb lock.	\$36.00

\* Price includes fitted case.

## Heavy Duty Vernier Caliper

Made of hardened stainless steel throughout, ground and lapped for accuracy. The open-face design permits both vernier scales to be located on one side of the gage for inside and outside measurements. Longer jaws permit greater accessibility and simpler measurement of larger work-pieces. Micro adjustment screw. Upper vernier reads in 1/20mm, lower in 1/1000.

6

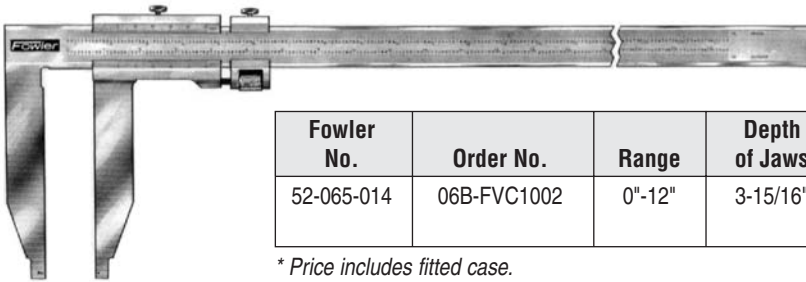

Fowler No.	Order No.	Range	Depth of Jaws	Description	Price*
52-065-014	06B-FVC1002	0"-12"	3-15/16"	Heavy Duty Plain Jaw Type Caliper	\$140.00

\* Price includes fitted case.

## Vernier Calipers With Knife Points With Fine Adjustment Screw • Helios™ Brand • Made in Germany

This is a larger version of No. 52-058-016 above, except longer range with deeper jaws and points.

### Special Features:

- Stainless Steel-Satin Chrome Finish
- Outside and inside measurements possible
- Micro adjustment screw
- Large verniers for easy reading
- Heavy-duty construction--hardened throughout
- Ground and lapped jaws
- Scales read 1/1000" - 1/128"



Fowler No.	Order No.	Range	Depth of Jaws	Description	Price*
52-075-008	06B-FVC1008	0"-8"	2-3/8"	Heavy-Duty Caliper with Knife Points	<del>\$167.00</del>

\* Price includes fitted case.

**\$83.75**



# Falcon Calipers • Depth Gage

## • Depth Micrometer

### Vernier Calipers for Large Measurements With Fine Adjustment Screw

These calipers are of the highest quality and accuracy to ensure the utmost in vernier measurement.

**Special Features:**

- Stainless Steel-Satin Chrome Finish
- Outside and inside measurements possible
- Micro adjustment screw
- Large verniers for easy reading
- Heavy-duty construction — hardened throughout
- Ground and lapped jaws
- Scales read 1/1000" - 1/128"

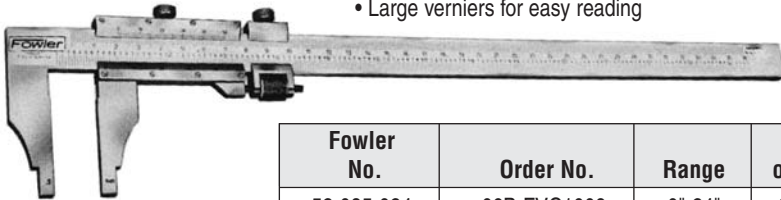

Fowler No.	Order No.	Range	Depth of Jaws	Description	Price*
52-085-024	06B-FVC1009	0"-24"	3-9/16"	Heavy-Duty Plain Jaw Type Caliper	\$614.00

\* Price includes fitted case.

### Vernier Depth Gage

Fowler's Vernier Depth Gage is an extremely useful tool for measuring the depths of holes, slots and recesses. It features an extra wide base for proper contact.

**Special Features:**

- Made of hardened chrome steel — satin chrome finish
- Measuring surface totally hardened and ground for maximum accuracy
- Accuracy guaranteed within 1/1000"

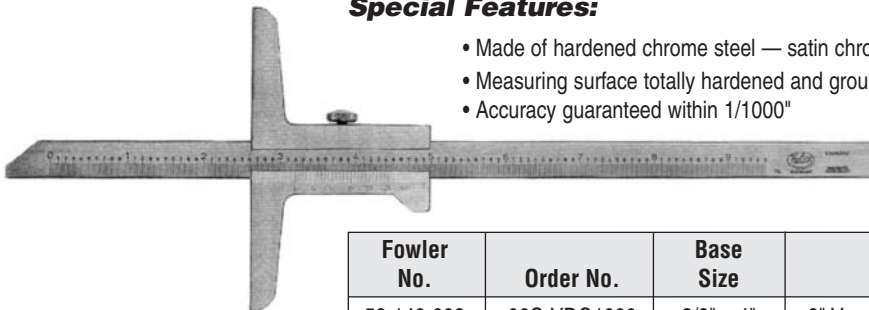

Fowler No.	Order No.	Base Size	Description	Price*
52-140-008	06C-VDG1000	3/8" x 4"	8" Vernier Depth Gage with single set screw	\$95.00

\* Price includes fitted case.

### Precision Micrometer Depth Sets

**Special Features:**

- Measuring tops are bright hard chrome finish, and therefore not liable to wear
- Bottom surfaces of base are hardened
- The interchangeable rods are fitted to the micrometer spindle against a positive stop and locked. This setting is carried out on a surface plate, using gage blocks
- The rods are hardened ground and lapped
- Threads are hardened ground and lapped for accuracy
- Ratchet stop



Fowler No.	Order No.	Range in Thousandths	Description	No. of Rods	Price*
52-225-010	06E-MIC1001	0"-3"	Depth micrometer with 4" base	3	\$129.00
52-225-015	06E-MIC1002	0"-6"	Depth micrometer with 4" base	6	\$158.00

\*Prices include fitted wooden case.

To order: specify Falcon Order No. and quantity. • Tel: 800-321-8512 • Fax: 216-328-1180

6



# Falcon Micrometers

## Micrometers • All with Carbide Measuring Surfaces

For hard-to-get-at places, the 52-230 series of outside micrometers feature a tapered steel frame. The heat insulated frame makes it an ideal tool to use in areas where the temperature is a factor.

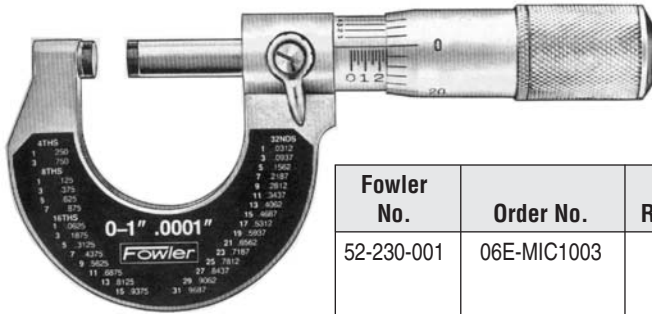

### Special Features

- These are high-grade micrometers made to the highest standards
- Anvil and spindle are made of special Swedish micrometer steel and hardened, ground, and lapped for extra accuracy. Accuracy is maintained at .00005" -- Parallelism to .00005" for 0-1"
- The measuring surfaces are carbide
- Thimble and barrel are finished in dull chrome to insure ease in reading graduations

Fowler No.	Order No.	Range	Graduations	Description	Price*
52-230-001	06E-MIC1003	0-1"	.0001"	Insulated forged frame Micrometer with positive locking clamp, adjustable nut & friction thimble. Carbide tipped	\$89.00
52-230-002	06E-MIC1004	1"-2"	.0001"	Same as above with standard	\$98.00

\* Price includes fitted case.

## Forged Frame All Chrome Micrometers

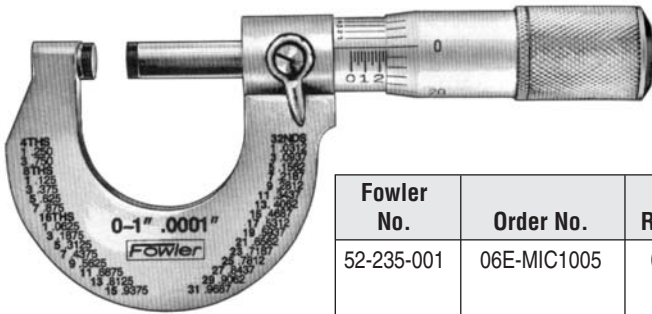

An advanced design micrometer series featuring superior quality, perfect balance and full finish tapered frame.

Fowler No.	Order No.	Range	Graduations	Description	Price*
52-235-001	06E-MIC1005	0"-1"	.0001"	Micrometer with positive locking clamp, adjustable nut and friction thimble. Carbide tipped	\$89.00
52-235-002	06E-MIC1006	1"-2"	.0001"	Same as above with standard	\$99.00

\* Price includes fitted case.

## Micrometers • All with Carbide Measuring Surfaces

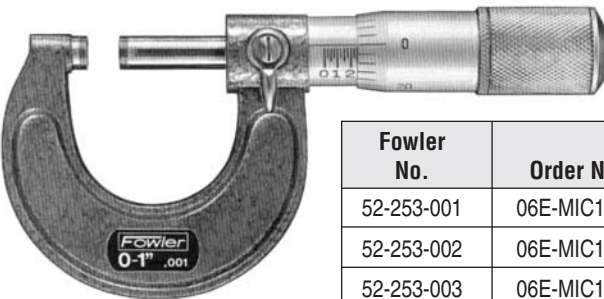

Fowler micrometers are of the finest quality available — at prices that defy competition. Special care in design and workmanship create a long lasting precision tool.

Fowler No.	Order No.	Range	Graduations	Thimble Type	Price*
52-253-001	06E-MIC1027	0-1"	.001"	Friction	\$70.00
52-253-002	06E-MIC1028	1-2"	.001" with standard	Friction	\$84.00
52-253-003	06E-MIC1029	2-3"	.001" with standard	Friction	\$99.00
52-253-004	06E-MIC1030	3-4"	.001" with standard	Friction	\$115.00
52-240-001	06E-MIC1007	0-1"	.0001"	Friction	\$77.00
52-240-002	06E-MIC1008	1-2"	.0001" with standard	Friction	\$90.00

\*Above prices include standards and fitted case.

6



# Falcon Micrometers • Thickness Gage

## Micrometer Set • All with Carbide Measuring Surfaces



### Special Features:

- Microfine graduations .0001" easy to read on satin chrome finish
- Positive lever locking clamps
- Carbide tips on every size, with a microlap finish on the measuring faces
- 1" and 2" sizes feature friction thimbles; larger sizes have ratchet stops
- Spindle thread hardened, ground and lapped. Anvil & spindle hardened and ground
- Quick, easy zero adjustment on sleeve
- Hammertone blue baked enamel frames
- Meets or exceeds Federal accuracy specs

Fowler No.	Order No.	Range	Description	Price*
52-215-003	06E-MIC9000	0-3"	Set, consisting of 3 micrometers 52-240-001 through 003	\$265.00

\*Above price includes standards and fitted case

## Pass Type Inside Measuring Micrometer



### Special Features:

- Inside micrometer with caliper type jaws for accurate internal measurements
- Frame designed to enable the micrometer to make small internal measurements
- Measuring surfaces are of rust proof steel hardened and ground on a radius to provide accurate measurement and prevent locking
- Threads of spindle are hardened and ground for extreme accuracy
- Black graduations on satin chrome finish for easy reading
- Ratchet stop for accurate "feel"
- Clamp screw

Fowler No.	Order No.	Range	Description	Price*
52-275-001	06E-MIC1031	0.2"-1"	Pass type micrometer	\$150.00
52-275-002	06E-MIC1032	1"-2"	Pass type micrometer	\$163.00

\*Prices include fitted wooden case

## Dial Thickness Gage

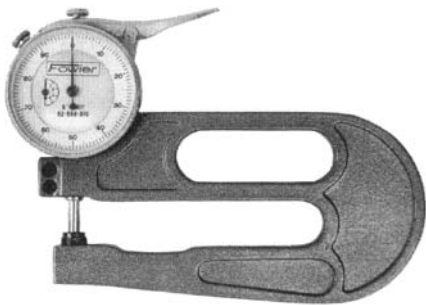

A precision built instrument of exceptionally high quality. Considered a must where accuracy is demanded. For use in measuring thicknesses of paper, cellophane, plastic film and metal plates. A specially built gage mounted in a hand-grooved stand with a thumb release mechanism.

### Special Features:

- Dull chrome plated dial indicator case
- Enameled frame
- Measuring faces of hi-grade tool steel, hardened, ground and lapped for accuracy
- Spindle of hardened stainless steel
- Reading direct 0-100 (with revolution counter)
- Supplied in a deluxe velvet-lined case
- Clear black graduations in .001"

Fowler No.	Order No.	Range	Throat Capacity	Graduations	Price
52-550-010	06I-DTG1001	.5"	4-3/4"	0.001	\$130.00

To order: specify Falcon Order No. and quantity. • Tel: 800-321-8512 • Fax: 216-328-1180



## Precision Bevel Protractor with Vernier Reading in 5 Minutes of Arc



### Special Features:

- This protractor is made of stainless steel throughout
- Dial face and vernier are finished in satin chrome to insure easy reading
- Protractor Dial is graduated over 360° (in 0° to 90° sectors) and rotates around the full circle. Readings to 5 minutes of arc with vernier
- Blade slides full length. 6" and 12" blades are available as extras, along with a full line of accessories. A magnifier is supplied with each instrument so as to facilitate reading of the ultra fine divisions of the vernier and dial

Fowler No.	Order No.	Description	Price
52-440-012	06F-PRO1001	Bevel protractor with 12" blade and special magnifier in fitted wooden case.	\$165.00

## Protractors for Measuring Angles from 0° to 180°



Fowler No.	Order No.	Description	Price
52-450-005	06F-PRO1006	Measures 3-5/16" in diameter and has a 6" ruler. Made of Chrome Steel, Satin Chrome Finish. Has an Adjusting Screw.	\$38.00

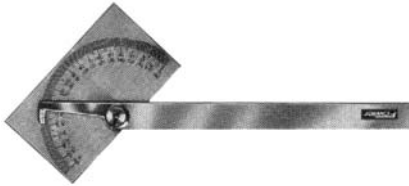

Fowler No.	Order No.	Description	Price
52-450-010	06F-PRO1007	Measures 3-5/16" x 2" and has a 6" ruler. Made of Chrome Steel, Satin Chrome Finish. Has an Adjusting Screw.	\$42.00

6

## Standard High Precision Dial Test Indicators



### A Comprehensive Line of Indicators Affording Easy Accurate Reading Under All Conditions

#### Special Features:

- May be mounted by means of dovetail or jig borer attachment as well as by regular holder, thus providing maximum versatility
- Friction contact point swivels through 180°
- Lever and crown movements, plus the use of jeweled bearings, insure exceptional sensitivity and repeatability
- Adjustable dial for zero setting
- Each instrument is furnished complete with clamp, adapter, and universal holder, and is packed in a fitted case

Fowler No.	Order No.	Reading	Value of Graduations	Inches	Dial Diameter	Jeweled	Length of Stylus	Price
52-555-005	06G-DTI1000	0-15-0	.0005	.030	1"	No	.306"	\$72.00
52-555-010	06G-DTI1001	0-15-0	.0005	.030	1"	Yes	.375"	\$90.00

To order: specify Falcon Order No. and quantity. • Tel: 800-321-8512 • Fax: 216-328-1180



# Falcon Magnetic Stand • Gage Sets • Center Finder

## Magnetic Stand



**For Positioning Dial Indicators or as a Surface Gage and for Transferring Measurements by Test Indicators.**

### Special Features:

- Heavy magnetic base attaches instantly to face plate, lathe or milling machine beds, etc. Exerts a magnetic pull of more than 85 lbs.
- On and off switch is conveniently located
- Quick adjustment clamp and universal holder with long extended arm

Fowler No.	Order No.	Overall Height	Diameter of Column	Description	Price
52-585-010	06J-MST1001	9.5"	.550"	Extra Heavy Column for utmost rigidity. Magnetic Power 85 lbs.	\$45.00

## Small Hole Gage Set



### Special Features:

- For accurate measurements of small holes, bores, or grooves, these tools are indispensable
- The gaging surface is a half ball with a flat bottom to permit measurements in very shallow places
- Knurled knob at the handle "locks" the "dimension" in, and final measurement is obtained by measuring over the balls with a micrometer. Measuring surfaces are fully hardened

Mitutoyo No.	Order No.	Description and Range	Price
154-901	06K-HGS1000	Set consists of four rods, packed in plastic case, having the following ranges: .125"-.2"; .2"-.3"; .3"-.4"; .4"-.5"	\$79.85

## Telescoping Gage Set



### Special Features:

- These gages enable one to measure accurately and inexpensively in places where otherwise nothing but very expensive bore gages or inside micrometers can be used
- Plunger of gage expands from the center, under spring tension, to the size of the hole being measured, and is then locked in place by knurled knob. Measurement can then be obtained by a micrometer or vernier caliper
- The end of the rods are hardened and ground on the radius of the smallest hole that the gage will enter

Fowler No.	Order No.	Description and Range	Price
52-470-005	06K-HGS1001	Set consists of five telescoping gages, packed in leatherette case in the following ranges: 1/2"-3/4"; 3/4"-1-1/4"; 1-1/4"-2-1/8"; 2-1/8"-3-1/2"; 3-1/2"-6"	\$76.00

## Center Finder



**To accurately find position of Tool Spindle in relation to work surfaces, layout lines, holes, slots, etc.**

### Special Features:

Set consists of four interchangeable attachments and special chuck: Needle point attachment, Ball contact attachment (.250" diam.), Disc contact attachment (.100" diam.), and Offset indicator holder.

Fowler No.	Order No.	Description	Price	Price Per Box of 12
52-575-005	06Z-MSC1400	Center Finder-Complete Set with Four Attachments	\$18.00	\$198.00

6

To order: specify Falcon Order No. and quantity. • Tel: 800-321-8512 • Fax: 216-328-1180



# Falcon Precision Squares

## • Screw Pitch Gage

### Precision Beveled Edge Fully Hardened Squares

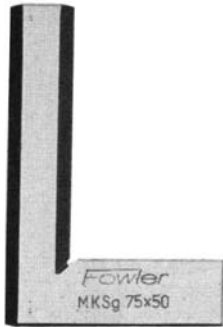

- These squares are for very exacting work. Made from a single piece of fully seasoned tool steel
- Blades are beveled on both edges of each side
- Squares are accurate right angles both inside and outside. Beams and blades are ground and accurately lapped for straightness and parallelism. Accuracy Class 1
- Squares are fully hardened (Rockwell 55)
- Length of blade is measured from inner edge of beam to end of blades

Fowler No.	Order No.	Type	Length Of Blade	Length Of Beam	Price
52-426-006	06L-SQU1013	Beveled	6-3/4"	4"	\$42.00
52-426-008	06L-SQU1003	Beveled	8-1/2"	5-1/8"	\$110.00

Above packed in individual cartons.

### Precision Fully Hardened Squares

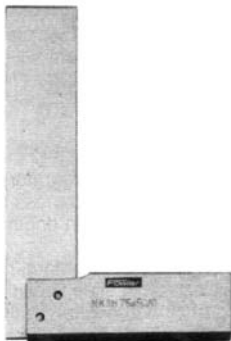

- These squares are of extra heavy construction, and made from fully hardened tool steel throughout
- Squares are accurate right angles both inside and outside. Beams and blades are ground and accurately lapped for straightness and parallelism. Accuracy Class 1
- Squares are fully hardened (Rockwell 55)
- Length of blade is measured from inner edge of square

Fowler No.	Order No.	Type	Length Of Blade	Length Of Beam	Price
52-431-002	06L-SQU1004	Plain	2-3/8"	1-3/8"	\$24.00
52-431-005	06L-SQU1006	Plain	5"	3"	\$68.00
52-431-006	06L-SQU1007	Plain	6-3/4"	4"	\$94.00
52-431-008	06L-SQU1008	Plain	8-1/2"	5-1/8"	\$104.00

Above packed in individual cartons.

### Standard Machinists Steel Squares



- Made of the finest Sheffield steel
- Designed for precision layout and measurement work of extreme accuracy
- Squares are true right angles, both inside and outside
- Beams and blades are ground and accurately lapped for straightness and parallelism
- Length of blade is measured from inner edge of beam to end of blades
- Blade is hardened

Fowler No.	Order No.	Type	Length Of Blade	Length Of Beam	Price
52-432-006	06L-SQU1010	Plain	6"	4"	\$20.00

Above packed in individual cartons.

### Screw Pitch Gage



Fowler No.	Order No.	Description	Price	Price per box Of 12 sets
52-485-015	06Z-MSG1300	Gage with 30 blades from 4 to 42 pitch standard V thread.	\$9.00	\$99.00

To order: specify Falcon Order No. and quantity. • Tel: 800-321-8512 • Fax: 216-328-1180



# Falcon Radius Gage Set • Sine Bar & Plate • Planer & Shaper Gage

## Radius Gage Set

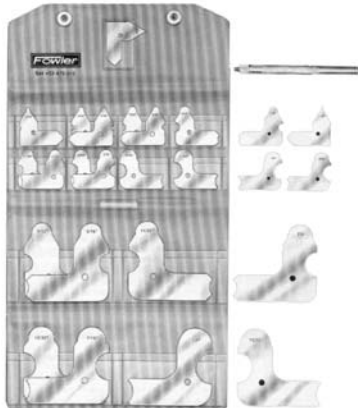

### Special Features:

- Made of rust-proof steel. Set consists of 25 individual gages, which can be used separately, thus insuring maximum accuracy
- Each gage is marked with its radius
- Each gage has five measuring surfaces for convex and concave radii
- A handy holder is included with each set
- Set is packed in handy leatherette holder

Fowler No.	Order No.	Description	Price per Set
52-470-010	06Z-MSC1200	25 gage set, from 1/64" to 1/2" by 64ths and 32nds. Including holder in leatherette case.	\$66.00

## Sine Bars • Sine Plates



### Special Features:

- The sine bar and rolls are hardened and ground for extreme accuracy
- The center to center distance "L" is accurate within .0001"
- The top surface is accurate to .0003" per inch of length
- Parallelism .0001"
- There is a flange on the end for resting work
- Various size holes are furnished to facilitate clamping
- A special feature of the tool is that the bottom part of the bar protrudes lower than the bottom of the "rolls" so that when the tool is moved about the surface plate all wear is eliminated from the rolls
- The 10" sine bar and 5" sine plate have some tapped holes for holding down
- A chamois is furnished with each bar to keep it clean and avoid tarnish
- A certificate of accuracy is furnished

Fowler No.	Order No.	Description	Width	Distance Between Center Of Rolls	Price
52-455-015	06M-SIN1001	10" tool steel hardened and ground sine bar	1"	10"	\$235.00
52-455-020	06M-SIN1002	5" tool steel hardened and ground sine plate	2"	5"	\$158.00

## Planer & Shaper Gage

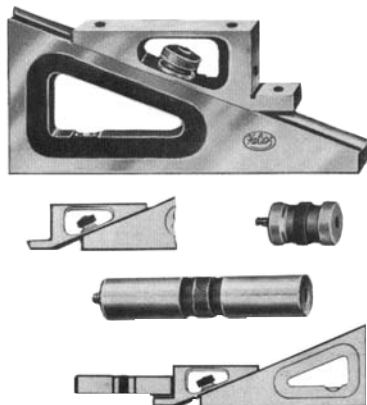

**The quickest and most accurate way of setting tools in the milling machine, planer, etc.**

### Special Features:

- Base and slide are beveled to provide accurate alignment and parallelism
- Base and slide are hardened
- Precision level insures accuracy
- Platform has extra tapped holes to accommodate post for dial indicators and other accessories

Fowler No.	Order No.	Description	Price*
52-460-005	06Z-MSC1100	Planer and Shaper Gage with precision level. Packed in fitted wooden case.	\$295.00

\* Price includes case

Range is from 1/4" to 6-1/4". Extension is 3" long.

**To order: specify Falcon Order No. and quantity. • Tel: 800-321-8512 • Fax: 216-328-1180**



# Falcon Optical Comparator

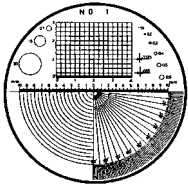

No. 1 (52-667-001)

**Order No.**  
06N-OPT5001

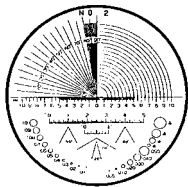

No. 2 (52-667-002)

**Order No.**  
06N-OPT5002

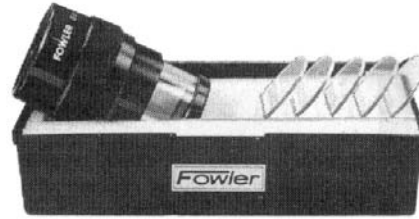

## Optical Comparator

A measuring and inspection comparator for the machinist, tool maker, inspector and laboratory technician.

For the lithographer, printer and photo engraver.

An optimum quality-triple element Kellner achromatic lens of 7x power magnification in a focusing mount for inspection use in plate-making, photo-engraving, etching, as well as checking dot formation in lithography work. Precision ground lens allows sharp undistorted images, completely free of aberrations.

Widely used by machinists, toolmakers, and inspectors for checking angles, thread measurements, hole sizes, etc. Has many uses in the machine shop, tool room, and at the inspection bench.

### Special Features:

- The scales are photo etched into a glass reticle, which is placed in actual contact with the measured object, thus obtaining simultaneous enlarged images of the scale and measured object. Highly accurate measurements are thus obtained. Can be used also as a high grade magnifier
- Thirteen types of glass reticles are available
- These are interchangeable in the screw-in mount on the bottom unit. With them, measurements of diameter, radius, angle, and thickness can be made
- In fitted case



No. 3 (52-667-003)

**Order No.**  
06N-OPT5003

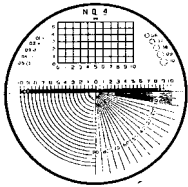

No. 4 (52-667-004)

**Order No.**  
06N-OPT5004

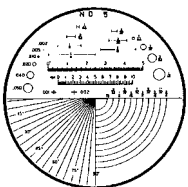

No. 5 (52-667-005)

**Order No.**  
06N-OPT5005

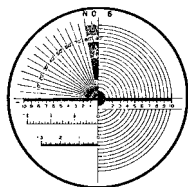

No. 6 (52-667-006)

**Order No.**  
06N-OPT5006

6

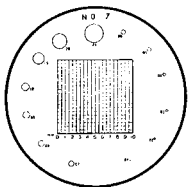

No. 7 (52-667-007)

**Order No.**  
06N-OPT5007

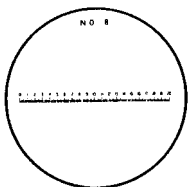

No. 8 (52-667-008)

**Order No.**  
06N-OPT5008

Fowler No.	Order No.	Description	Price
52-665-001	06N-OPT1000	7x Comparator with No. 5 Reticle in fitted case.	\$58.00
52-665-005	06N-OPT1001	7x Comparator in fitted case with 5 Reticles, Nos. 1, 5, 7, 8, 13	\$118.00
		Other Reticles	\$13.00

\*NOTE: Any other assortment of 5 Reticles can be substituted on above.

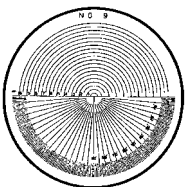

No. 9 (52-667-009)

**Order No.**  
06N-OPT5009

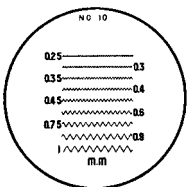

No. 10 (52-667-010)

**Order No.**  
06N-OPT5010

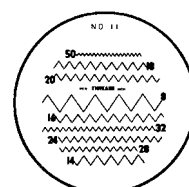

No. 11 (52-667-011)

**Order No.**  
06N-OPT5011

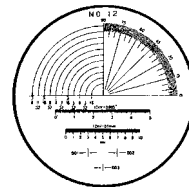

No. 12 (52-667-012)

**Order No.**  
06N-OPT5012

No. 13 (52-667-013)

**Order No.**  
06N-OPT5013

.600" range in .01" (same as No. 8 except in inches)

To order: specify Falcon Order No. and quantity. • Tel: 800-321-8512 • Fax: 216-328-1180



# Falcon Gage Blocks

## • Instant Height Gage

### Falcon Gage Blocks

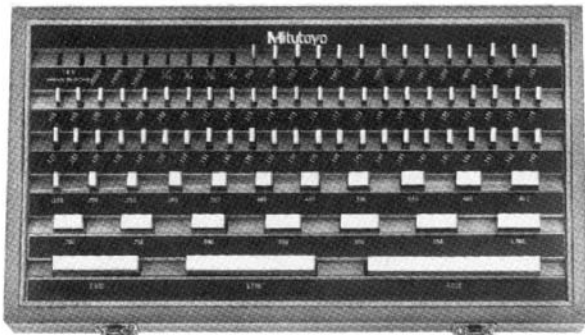

#### Special Features:

- Constructed of a special steel of high carbon & chrome content, hardened to 65RC, ensures hard wear resistance and stability
- Manufactured under carefully controlled conditions to ensure maximum accuracy, parallelism and flatness
- Calibrated to specifications which meet or exceed Fed. Spec. GGG-G-15
- Sets include certification traceable to the National Institute of Standards & Technology
- Surface finish: .4 millionths (.01 microns)

Sets		Fowler No.	Order No.	Inspection Grade Accuracy +5 millionths inch -2 millionths inch
<b>81 PIECE SET</b> <i>Consisting of the following blocks:</i>	9 blocks from .1001" to .1009" 49 blocks from .101" to .149" 19 blocks from .050" to .950" 4 blocks from 1.000" to 4.000"	53-671-028	06Q-GAG1000	<b>\$1,500.00*</b>
<b>36 PIECE SET</b> <i>Consisting of the following blocks:</i>	1 block .05005" 9 blocks from .0501" to .0509" 9 blocks from .051" to .059" 10 blocks from .050" to .150" 5 blocks from .100" to .500" 2 blocks from 1.000" to 2.000"	53-671-038	06Q-GAG1002	<b>\$828.65*</b>

\*Prices include fitted wooden case.

6

### Instant Height Gage

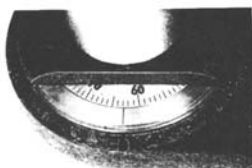
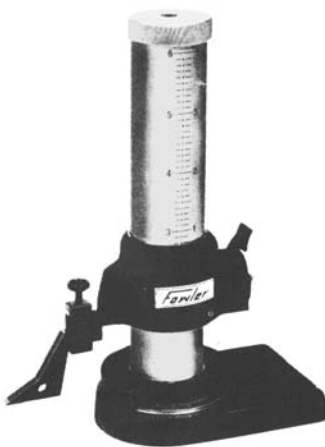

#### Special Features:

- Eliminates all optical reading errors of a vernier by the use of a highly accurate micrometer that can be set and locked to the desired dimension
- Cut setting time by 85%
- Equipped with a combination carbide scriber and dial indicator holder. By turning this scriber upside down, the capacity of the unit is increased by "two inches"
- Highly accurate "check gage" for setting dial indicators and other gages
- All measuring surfaces are hardened, ground and lapped to a "gage block" finish
- Backlash is eliminated by a special thrust bearing
- Quick adjustment is made by pressing the lug in the back of the unit and moving the saddle up or down to the desired "tenth" inch where it locks itself in by releasing the lug
- Fine adjustment is made by turning the micrometer thimble (on top of the unit) one-half circle in a clockwise or counter-clockwise direction to the desired 1/1000-inch increment on the large dial on the bottom of the gage
- Micrometer shaft turns freely on a specially designed ball bearing race
- Micro-fine black graduations on a satin chrome finish for easy reading and each 0.1" is numbered

Fowler No.	Order No.	Range	Vernier Scale	Price*
52-180-006	06Z-MSC1500	6"	1/1000"	<b>\$450.00</b>

\*Prices include fitted case.

To order: specify Falcon Order No. and quantity. • Tel: 800-321-8512 • Fax: 216-328-1180



# Mitutoyo Micrometers

## Friction Thimble Type

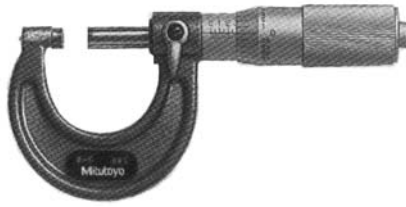

### Outside Micrometers Series 103

- Accuracy .0001"
- Parallelism from .00005"
- Every thousandth is numbered for easy reading
- Crisp, clear graduations
- Diameter of measuring faces .250"
- Flatness .00003"
- Enameled frame
- Anvil and spindle hardened and precision ground — with microlap finish on ends
- Carbide faces
- Friction thimble for exact and repetitive readings
- Quick and easy wear-adjustment
- Positive locking clamp

Range	Mitutoyo No.	Order No.	Graduation	Price*
English 0-1"	103-127	06R-MMC1002	.001"	<b>\$79.80</b>
1-2"	103-128 with standard	06R-MMC1003	.001"	<b>\$93.70</b>
0-1"	103-135	06R-MMC1004	.0001"	<b>\$89.10</b>
1-2"	103-136 with standard	06R-MMC1005	.0001"	<b>\$103.00</b>

\*Prices include carrying case.

## Ratchet Stop Type



### Outside Micrometers Series 103

- Accuracy .0001"
- Parallelism from .00005"
- Every thousandth is numbered for easy reading
- Diameter of measuring faces:  
.250", 0" to 12"  
.315", 12" to 24"
- Flatness .00003"
- Enameled frame
- Anvil and spindle hardened and precision ground — with microlap finish on ends
- Carbide faces
- Ratchet stop for exact and repetitive readings
- Crisp, clear graduations
- Quick and easy wear-adjustment
- Positive locking clamp

Range	Mitutoyo No.	Order No.	Graduation	Price
0-1"	103-259	06R-MMC1028	.001"	<b>\$79.80</b>
0-1"	103-260	06R-MMC1029	.0001"	<b>\$87.60</b>
1-2"	103-262	06R-MMC1030	.0001" with standard	<b>\$102.50</b>
2-3"	103-217	06R-MMC1018	.0001" with standard	<b>\$114.30</b>
3-4"	103-218	06R-MMC1019	.0001" with standard	<b>\$130.80</b>
4-5"	103-219	06R-MMC1020	.0001" with standard	<b>\$142.10</b>
5-6"	103-220	06R-MMC1021	.0001" with standard	<b>\$156.60</b>
6-7"	103-221	06R-MMC1022	.0001" with standard	<b>\$178.20</b>
7-8"	103-222	06R-MMC1023	.0001" with standard	<b>\$187.50</b>
8-9"	103-223	06R-MMC1024	.0001" with standard	<b>\$207.00</b>
9-10"	103-224	06R-MMC1025	.0001" with standard	<b>\$216.30</b>
10-11"	103-225	06R-MMC1026	.0001" with standard	<b>\$225.60</b>
11-12"	103-226	06R-MMC1027	.0001" with standard	<b>\$233.80</b>

6



To order: specify Falcon Order No. and quantity. • Tel: 800-321-8512 • Fax: 216-328-1180



## Digit-Outside Micrometers



### Direct Digital Read-Out Series 193

- Flatness .00003"
- Parallelism .00005" for 0-1" range models
- Accuracy .0001"
- Carbide measuring faces
- Positive locking nut
- Friction thimble stop assures uniform contact pressure for 1" and 2" digit-micrometers
- Ratchet stop for 3" and 4"
- Anvil and spindle hardened and precision ground with micro-lap finish on ends
- Quick and easy zero adjustment
- Clear graduations on satin chrome finished thimble
- Spanner wrench furnished with each micrometer
- Diameter of measuring face: .250"
- Complete with fitted carrying case

Mitutoyo No.	Order No.	Range	Graduation	Price
193-211	06R-MMC1031	0-1"	.0001"	<b>\$137.00</b>
193-212	06R-MMC1032	1-2"	.0001" with standard	<b>\$160.70</b>
193-213	06R-MMC1033	2-3"	.0001" with standard	<b>\$181.30</b>
193-214	06R-MMC1034	3-4"	.0001" with standard	<b>\$199.80</b>

## Micrometer Set

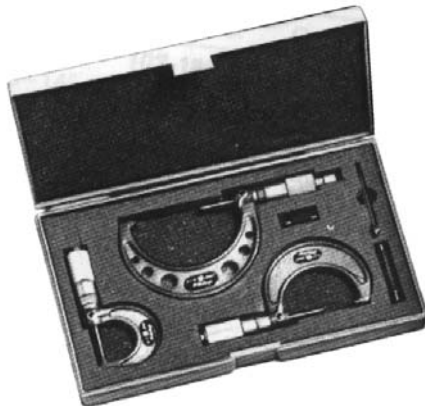

### Outside Micrometers Series 103

- Enameled frame
- Accuracy from .0001"
- Anvil and spindle hardened and precision ground — with micro-lap finish of ends
- Carbide faces
- Friction thimble of exact and repetitive readings up to 2". Larger tools all with ratchet stops
- Crisp, clear graduations
- Positive locking clamp
- Every micrometer has every thousandth numbered
- All sets are supplied complete with standard for each micrometer
- Quick and easy wear adjustment
- Inch set .0001" graduation

Mitutoyo Set No.	Order No.	Range	In Set	Price
103-922	06R-MMC9003	0-1"	103-135	<b>\$317.20</b>
3 micrometers		1-2"	103-136	
0-3"		2-3"	103-217	

## Vernier Height Gages

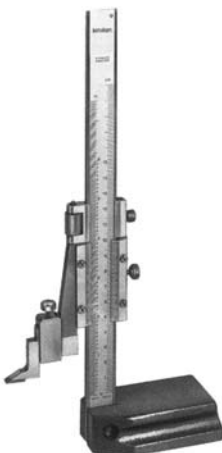

### With adjusting slide for fine adjustments

- Priced for the mechanic's pocketbook
- Beam and measuring slide of stainless steel
- Base and all measuring surfaces are hardened, ground and micro-lapped for accuracy
- Clear, crisp black graduations on a satin-chrome finish for easy reading and each 0.1" is numbered
- Raised sliding surfaces on main scale prevent defacement and wear of graduations
- Adjusting slide for easy setting
- Marker clamp also accepts test indicator bars (No. 900306) readily
- Carbide tipped offset marker included

Range	Mitutoyo No.	Order No.	Vernier Reading	Base W&L	Price
10" Range	506-206	06U-MHG1002	.001"	2.35" x 4.0"	<b>\$291.50</b>



# Mitutoyo Calipers

The finest of vernier calipers for accurate work,  
with Mitutoyo's exclusive "Quardi" 4-way measuring feature.

## Dial Calipers

### Series 505 With ThumbRoll For Fast Adjustment

#### Special Features:

- Extra-rigid (3.4mm thick) main beam
- Extra-large dial face for easy reading
- Hardened stainless throughout
- Inside, outside, depth and step measurements
- Easy zero point re-adjustment with adjuster supplied

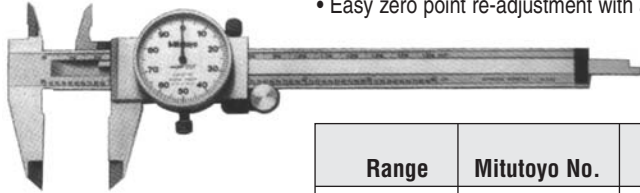

Range	Mitutoyo No.	Order No.	Grad.	Range per Rev.	Price*
Inch 4"	505-629	06S-MDC1003	.001	.200	\$76.20
6"	505-626	06S-MDC1000	.001	.200	\$88.20
8"	505-627	06S-MDC1001	.001	.200	\$131.80
12"	505-628	06S-MDC1002	.001	.200	\$197.80

\*Prices include fitted carrying case.

## Calipers

6



### Series 530 With Single Set Screw

Size	Mitutoyo No.	Order No.	Vernier Scale	Price
6"	530-105	06T-MVC1000	1/128" x .001"	\$76.70
8"	530-116	06T-MVC1001	1/128" x .001"	\$91.70
6"	530-314	06T-MVC1002	1/128" x .001"	\$91.70*

\*with carbide outside jaws



### Series 531 With Thumb Lock

Size	Mitutoyo No.	Order No.	Vernier Scale	Price
6"	531-113	06T-MVC1003	1/128" x .001"	\$78.80
8"	531-114	06T-MVC1004	1/128" x .001"	\$99.40



### Series 532 With Fine Adjustment

Size	Mitutoyo No.	Order No.	Vernier Scale	Price
5"	532-104	06T-MVC1005	1/128" x .001"	\$86.50
7"	532-105	06T-MVC1006	1/128" x .001"	\$99.40
11"	532-121	06T-MVC1007	.02mm x .001"	\$216.30

To order: specify Falcon Order No. and quantity. • Tel: 800-321-8512 • Fax: 216-328-1180